

THIS PRINT AND ALL INFORMATION APPEARING THEREON IS THE PROPERTY OF THE RBI DIVISION OF MESTEK INC. NEITHER THE PRINT NOR THE INFORMATION THEREIN MAY BE REPRODUCED OR USED IN ANY MANNER WHATSOEVER OR DIVULGED TO ANY OTHER PERSON UNLESS SPECIFICALLY AUTHORIZED BY MESTEK INC.

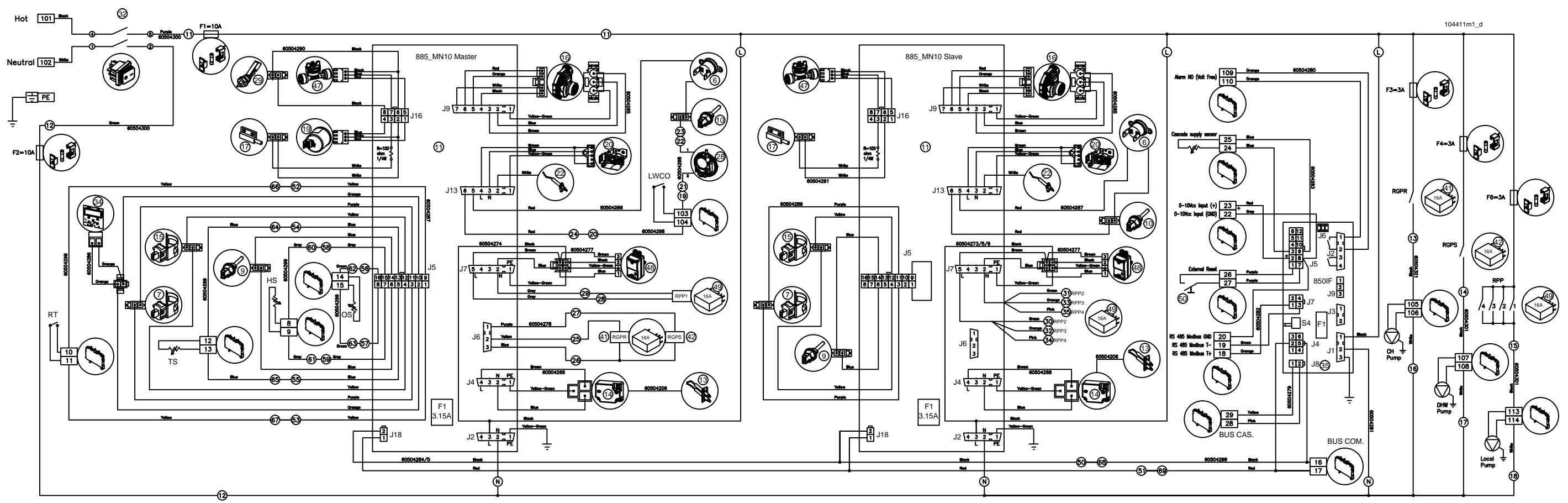

IE2-399 - 1000
WIRING DIAGRAM

SCALE:	NONE	SHEET:	1 of 3	DWG. SIZE:		DRAWING NUMBER:		P. #:	
DR. BY:		DATE:	3/5/14						
CHK. BY:		DATE:							
						42-9003			



- 1 - Air inlet
- 2 - Flue exhaust
- 3 - Automatic air vent
- 4 - Sealing chamber
- 5 - Three way valve (optional)
- 6 - High limit supply temperature switch
- 7 - Supply temperature sensor
- 8 - Purging cock
- 9 - Flue gas temperature sensor
- 10 - High limit flue gas temperature switch
- 11 - Control board
- 12 - Premix burner
- 13 - Ignition electrodes
- 14 - ignitor

- 15 - Return temperature sensor
- 16 - Modulating PWM fan
- 17 - Back flue preventer
- 18 - Section valve (optional)
- 19 - Water pressure sensor
- 20 - Gas valve
- 21 - Circulator pump
- 22 - Detection electrode
- 23 - Supply and return manifolds
- 24 - CRV Stainless steel heat exchanger
- 25 - Heating supply

- 26 - Heating return
- 27 - Gas supply
- 28 - Blocked flue pressure switch
- 29 - Condensing blocked drain switch
- 30 - Condensing drain
- 31 - Condensate Siphon
- 32 - Main electrical switch
- 33 - System temperature sensor
- 34 - Display
- 35 - Modbus interface board
- 36 - Condensate neutralizer
- 37 - CSD-1 safety devices:
 - ASME relief valve
 - Low water cut-off
 - High limit temperature switch
 - Temperature gauge
 - Pressure gauge

- 38 - Summer disable CH pump jump (when outdoor reset working all the time)
- 39 - Room thermostat relay
- 40 - 2 minutes timer
- 41 - CH pump relay
- 42 - DHW pump relay
- 43 - Relays for the control of the external pumps
- 44 - Enable parallel CH and DHW pump working
- 45 - Unit electrical switch
- 46 - 110 to 24Vca transformer
- 47 - Flow meter
- 48 - Motorized valve (optional)
- 49 - System pump relays
- 50 - External reset
- LWCO - Low water cut-off and all other CSD-1 safety devices connection
- CH Pump - Central heating pump
- DHW Pump - Indirect water heater pump

THIS PRINT AND ALL INFORMATION APPEARING THEREON IS THE PROPERTY OF THE RBT DIVISION OF MESTEK INC. NEITHER THE PRINT NOR THE INFORMATION THEREON MAY BE REPRODUCED OR USED IN ANY MANNER WHATSOEVER OR DISCLOSED TO ANY OTHER PERSON UNLESS SPECIALLY AUTHORIZED BY MESTEK INC.



IE2-399 - 1000
WIRING DIAGRAM

SCALE: NONE	SHEETS: 2 of 3	DWG. SIZE:	DRAWING NUMBER:	P. 5
DR. BY:	DATE: 3/5/14	OC. BY:	B 42-9003	-

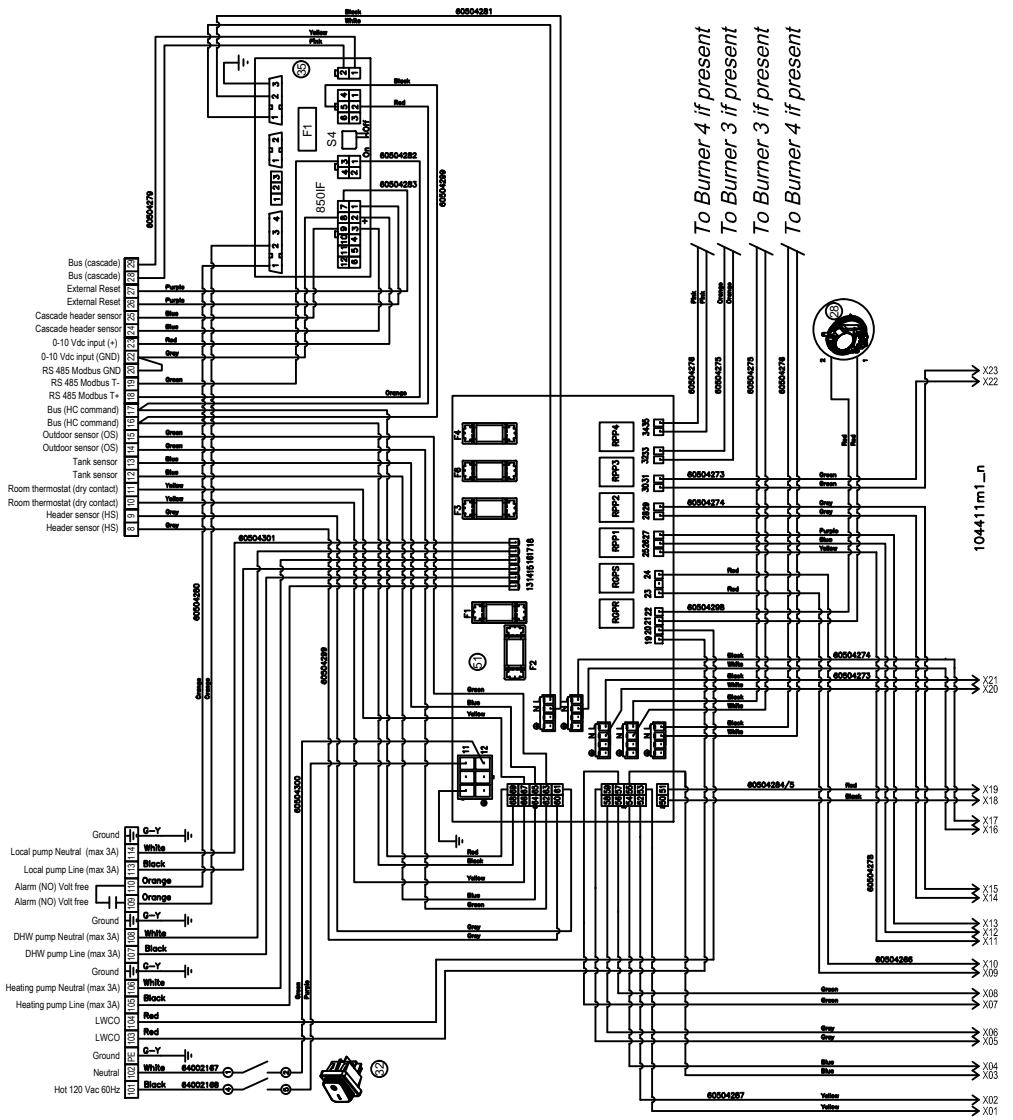

To Burner 4 if present
 To Burner 3 if present
 To Burner 4 if present

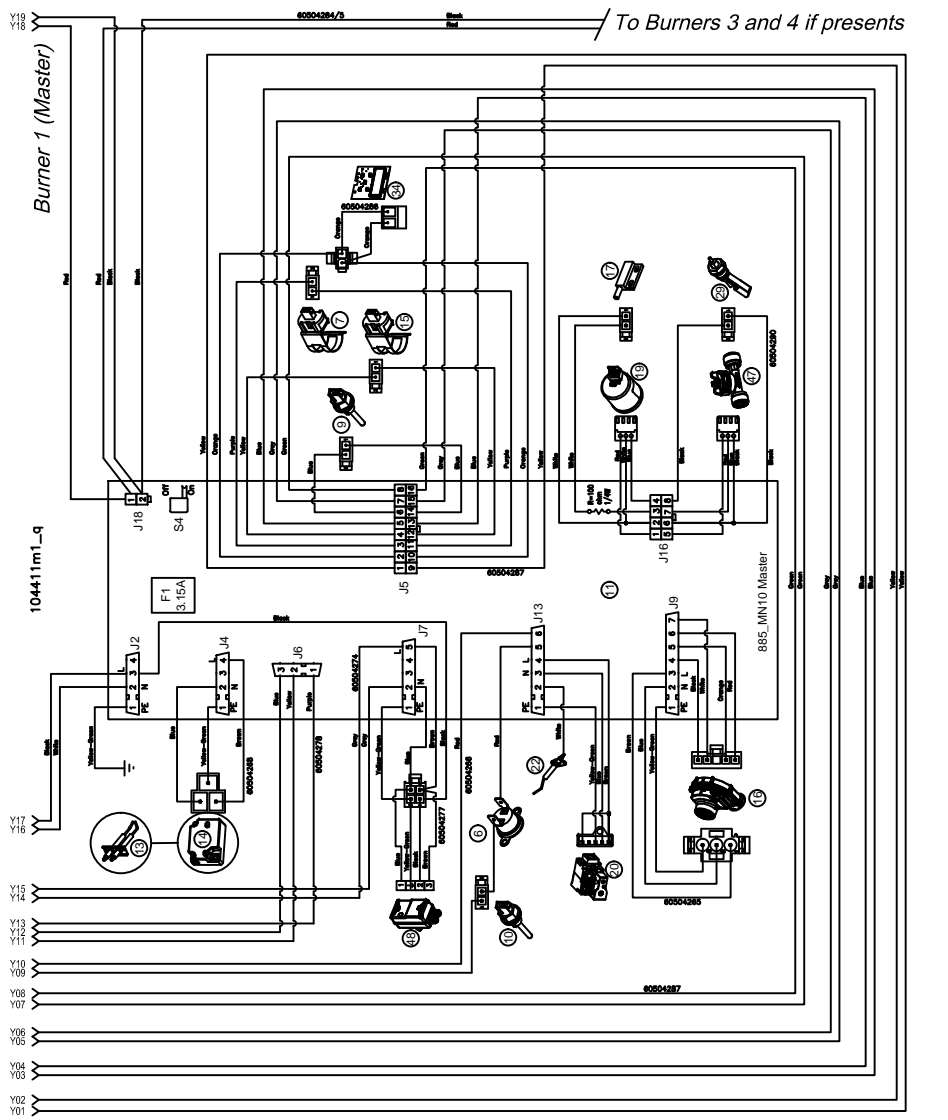
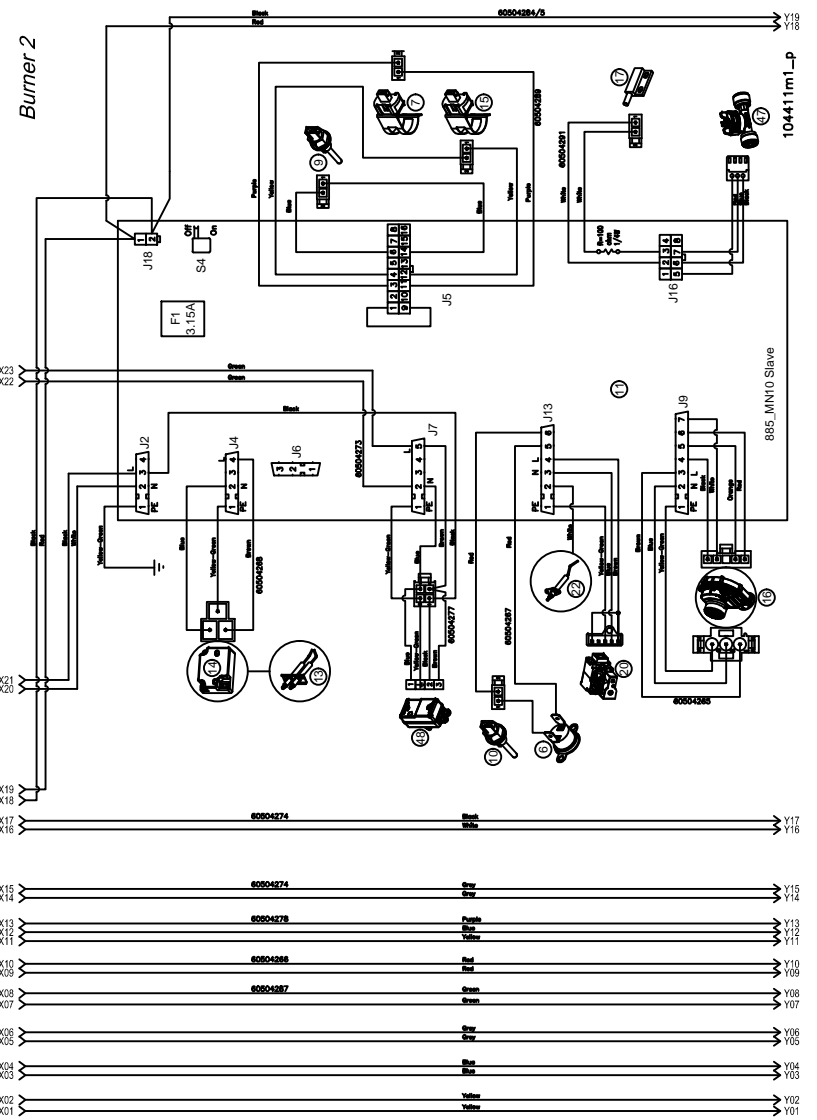

- 1 - Air inlet
- 2 - Flue exhaust
- 3 - Automatic air vent
- 4 - Sealing chamber
- 5 - Three way valve (optional)
- 6 - High limit supply temperature switch
- 7 - Supply temperature sensor
- 8 - Purging cock
- 9 - Flue gas temperature sensor
- 10 - High limit flue gas temperature switch
- 11 - Control board
- 12 - Premix burner
- 13 - Ignition electrodes
- 14 - Ignitor

- 15 - Return temperature sensor
- 16 - Modulating PWM fan
- 17 - Back flue preventer
- 18 - Section valve (optional)
- 19 - Water pressure sensor
- 20 - Gas valve
- 21 - Circulator pump
- 22 - Detection electrode
- 23 - Supply and return manifolds
- 24 - CRV Stainless steel heat exchanger
- 25 - Heating supply

- 26 - Heating return
- 27 - Gas supply
- 28 - Blocked flue pressure switch
- 29 - Condensing blocked drain switch
- 30 - Condensing drain
- 31 - Condensate Siphon
- 32 - Main electrical switch
- 33 - System temperature sensor
- 34 - Display
- 35 - Modbus interface board
- 36 - Condensate neutralizer
- 37 - CSD-1 safety devices:
 - ASME relief valve
 - Low water cut-off
 - High limit temperature switch
 - Temperature gauge
 - Pressure gauge

- 38 - Summer disable CH pump jump (when outdoor reset working all the time)
- 39 - Room thermostat relay
- 40 - 2 minutes timer
- 41 - CH pump relay
- 42 - DHW pump relay
- 43 - Relays for the control of the external pumps
- 44 - Enable parallel CH and DHW pump working
- 45 - Unit electrical switch
- 46 - 110 to 24Voa transformer
- 47 - Flow meter
- 48 - Motorized valve (optional)
- 49 - System pump relays
- 50 - External reset
- LWCO - Low water cut-off and all other CSD-1 safety devices connection
- CH Pump - Central heating pump
- DHW Pump - Indirect water heater pump

THIS PRINT AND ALL INFORMATION APPEARING THEREON IS THE PROPERTY OF THE RFI DIVISION OF MESTEK INC. NEITHER THE PRINT NOR THE INFORMATION THEREON MAY BE REPRODUCED OR USED IN ANY MANNER WHATSOEVER OR DIVULGED TO ANY OTHER PERSON UNLESS SPECIFICALLY AUTHORIZED BY MESTEK INC.



IE2-399 - 1000
 WIRING DIAGRAM

SCALE: NONE	SHEETS: 3 of 3	DWG. SIZE: B	DRAWING NUMBER: 42-9003	R/C: -
DR. BY: DATE	3/5/14			